



Most Widely Accepted and Trusted

ICC-ES Report

ESR-2037

ICC-ES | (800) 423-6587 | (562) 699-0543 | www.icc-es.org

Reissued 07/2015
This report is subject to renewal 07/2016.

DIVISION: 03 00 00—CONCRETE

SECTION: 03 37 00—SPECIALLY PLACED CONCRETE

REPORT HOLDER:

EMMEDUE S.P.A.

VIA TONIOLO 39/B
Z.I. BELLOCCHI, 61032 FANO (PU)
ITALY

EVALUATION SUBJECT:

EMMEDUE WALL, FLOOR AND ROOF PANEL



Look for the trusted marks of Conformity!

“2014 Recipient of Prestigious Western States Seismic Policy Council (WSSPC) Award in Excellence”



A Subsidiary of

ICC-ES Evaluation Reports are not to be construed as representing aesthetics or any other attributes not specifically addressed, nor are they to be construed as an endorsement of the subject of the report or a recommendation for its use. There is no warranty by ICC Evaluation Service, LLC, express or implied, as to any finding or other matter in this report, or as to any product covered by the report.



ICC-ES Evaluation Report

ESR-2037

Reissued July 2015

This report is subject to renewal July 2016.

www.icc-es.org | (800) 423-6587 | (562) 699-0543

A Subsidiary of the International Code Council®

DIVISION: 03 00 00—CONCRETE
Section: 03 37 00—Specialty Placed Concrete

REPORT HOLDER:

EMMEDUE S.P.A
VIA TONIOLO 39/B
Z. I. BELLOCCHI
61032 FANO (PU)
ITALY
(0039) 0721 855660
www.mdue.it
info@mdue.it

EVALUATION SUBJECT:
EMMEDUE WALL, FLOOR AND ROOF PANEL
1.0 EVALUATION SCOPE
Compliance with the following codes:

- 2012 and 2009 *International Building Code*® (IBC)
- 2012 and 2009 *International Residential Code*® (IRC)
- 2013 *Abu Dhabi International Building Code* (ADIBC)[†]

[†]The ADIBC is based on the 2009 IBC. 2009 IBC code sections referenced in this report are the same sections in the ADIBC.

Properties evaluated:

- Structural
- Surface-burning characteristics
- Fire resistance
- Weather resistance
- Physical properties

2.0 USES

Emmedue wall, floor and roof panels are used as structural composite panels for load-bearing and nonload-bearing concrete walls, and reinforced concrete floor and roof panels in fire-resistance-rated and non-fire-resistance-rated construction. The Emmedue panels are recognized for use in buildings of noncombustible construction when installed in accordance with Section 4.2 of this report.

3.0 DESCRIPTION
3.1 General:

The Emmedue panels consist of a single insulating foam plastic board with a grid of welded wire reinforcement on each face of the insulating panel connected by steel transverse wires. A layer of Shotcrete is applied to each face of the wall panels, over the welded woven steel, at the

jobsite. Emmedue wall panels are designated PSM80 and consist of 4-inch-thick (102 mm) EPS foam cores with 1-inch-thick (25.4 mm) Shotcrete on each outer face. The Emmedue floor-roof panels consist of an insulating foam plastic board with a layer of welded wire reinforcement on each face and a grid of welded wire reinforcement connected by steel transverse wires. The bottom of the floor-roof panels is shot with a layer of Shotcrete at the jobsite. The top of the floor-roof panels is covered with a layer of placed concrete at the jobsite. Emmedue floor-roof panels are designated PSS80 or PSS150 and consist, respectively, of 4-inch-thick (102 mm) or 6-inch-thick (152 mm) EPS foam cores, with 2 inches of concrete on the top surface and 1-inch (25.4 mm) Shotcrete on the bottom surface. The Emmedue wall panels and floor-roof panels are preformed and delivered to the jobsite for erection and placement of Shotcrete and concrete.

3.2 Materials:

3.2.1 EPS: The insulation used in the Emmedue wall, floor and roof panels is expanded polystyrene (EPS) foam plastic boards manufactured from EPS beads recognized in ICC-ES [ESR-1798](#). The EPS is Type I EPS with a minimum density of 0.90 pcf (14.4 kg/m³), a flame-spread index of 25 or less and a smoke-developed index of 450 or less when tested in accordance with ASTM E 84 at a 4-inch (102 mm) thickness and a 1.0 pcf (16.0 kg/m³) maximum density.

3.2.2 Reinforcement: Deformed steel reinforcement bars must have a minimum yield stress of 60 ksi (420 Mpa) and comply with Section 3.5.3.1 of ACI 318 and IBC Section 1903. Welded plain wire reinforcement must comply with Section 3.5.3.5 of ACI 318 and IBC Section 1903. The wire used in the fabrication of the welded wire reinforcement and the steel transverse wire conforms to ASTM A 82. The welded wire reinforcement complies with ASTM A 185.

3.2.3 Concrete: Concrete must be normal-weight concrete, complying with the applicable code, having a maximum aggregate size of ⁵/₈ inch (16 mm), a minimum slump of 2 inches (51 mm), and a minimum compressive strength of 2,500 psi (17.2 MPa) [minimum of 24 MPa is required under ADIBC Appendix L, Section 5.1.1] at 28 days. The concrete must comply with Chapter 19 of the IBC.

3.2.4 Shotcrete: Shotcrete must comply with IBC Section 1913 and have a minimum specified compressive strength of 2,500 psi (17.2 MPa) [minimum of 24 MPa is required under ADIBC Appendix L, Section 5.1.1]. Aggregate size must not exceed ³/₈ inch (9.5 mm) and conform to Gradation No. 1 of Table 2.1 of ACI 506R-90.

4.0 DESIGN AND INSTALLATION

4.1 Design:

Concrete walls, floors and roofs formed by the Emmedue system must be designed and constructed in accordance with Chapters 16 and 19 of the IBC. The design loads for walls and floors must not exceed the allowable loads set forth in Tables 1 and 2 of this report.

For each project, plans, specifications, and structural calculations must be submitted to the building official for approval, and must show particular job details relating to design and construction. The calculations must be based on loads and loading conditions as required in the IBC.

To ensure structural integrity, the Emmedue system must be subjected to a structural analysis, prior to construction, conducted by registered design professionals trained and certified by Emmedue. The structural analysis must be used to determine structural capacities for all portions of the Emmedue system.

4.2 Fire-resistive-rated Assemblies:

Wall panels constructed with up to 4-inch-thick (102 mm) EPS board cores and 1³/₄-inch-thick (44 mm) Shotcrete on each face have a one-hour fire resistance rating. The maximum allowable axial compressive load is 2,840 plf (41.5 kN/m), exclusive of the weight of the wall panel.

Floor-roof panels with a minimum concrete thickness of 1 inch (25.4 mm) on the underside and 2 inches (51 mm) on the topside have a one-hour fire-resistance rating when tested in accordance with ASTM E 119.

For applications on buildings of any height, floor-to-wall intersections must be fireblocked in accordance with the applicable code to prevent the passage of flame, smoke and hot gases from one story to another. The foam plastic insulation must not be continuous from one story to another.

4.3 Installation:

Foundation walls, footings, and other supporting structures receiving Emmedue panels must be level and free of dirt and loose material. Reinforcement for anchoring panels to support must be as shown on the plans.

The Emmedue panels are installed and aligned in accordance with the plans. After alignment, Shotcrete concrete complying with Section 3.2.4 of this report is applied to the welded wire reinforcement. The Shotcrete concrete must be applied to the outside and inside of the Emmedue wall panels and to the underside of the floor-roof panels to the thickness shown on the plans. The exterior and interior concrete must be applied by the

Shotcrete process, using either the “dry” or “wet” process in accordance with the provisions of the Guide to Shotcrete (ACI 506R-90) and the Specification for Shotcrete (ACI 506.2-95). Shotcrete application must comply with Section 1913 of the IBC.

The Shotcrete cover over the wall panel welded wire reinforcement must not be less than 1 inch (25.4 mm) in thickness, with a minus tolerance of 1/4 inch (6.4 mm).

4.4 Special Inspection:

Special inspection of Shotcrete must be in accordance with Table 1705.3 and Section 1910.10 of the 2012 IBC, or Table 1704.4 and Section 1913.10 of the 2009 IBC. Continuous inspection of poured concrete must be in accordance with Section 1704.4 of the IBC.

5.0 CONDITIONS OF USE

The Emmedue wall, floor and roof panel systems described in this report comply with, or are suitable alternatives to what is specified in, those codes listed in Section 1.0 of this report, subject to the following conditions:

- 5.1 Installation complies with this report, the manufacturer's published installation instructions and the applicable code. In the event of a conflict between the manufacturer's published installation instructions and this report, this report governs.
- 5.2 The structural concrete wall systems recognized in this evaluation report, when used as seismic force-resisting systems, must be limited to Seismic Design Category A or B under the IBC or IRC.
- 5.3 Installation of elements requiring special inspection under the IBC must comply with Section 4.4 of this report.
- 5.4 The panels are manufactured in Schieppe di Orciano, Italy, with inspections by ICC-ES.

6.0 EVIDENCE SUBMITTED

Data in accordance with the ICC-ES Acceptance Criteria for Concrete Floor, Roof, and Wall Systems and Concrete Masonry Wall Systems (AC15), dated February 2010, editorially revised December 2012.

7.0 IDENTIFICATION

The Emmedue panels are labeled with the Emmedue name, address, manufacturing address, and evaluation report number (ESR-2037).

TABLE 1—ALLOWABLE WALL PANEL LOADS

TYPE OF LOADING	TYPE OF PANEL	PANEL HEIGHT (ft)	AXIAL COMPRESSIVE LOADS (Pounds per linear foot)	TRANSVERSE LOADS (Pounds per square foot)
Axial Compression	PSM80	8	7750	---
	PSM80	10	7810	---
	PSM80	12	7880	---
	PSM80	14	7940	---
Transverse for Deflection Limit L / 120	PSM80	8	---	223
	PSM80	10	---	177
	PSM80	12	---	131
	PSM80	14	---	86
Transverse for Deflection Limit L / 180	PSM80	8	---	190
	PSM80	10	---	153
	PSM80	12	---	115
	PSM80	14	---	78
Transverse for Deflection Limit L / 240	PSM80	8	---	173
	PSM80	10	---	140
	PSM80	12	---	107
	PSM80	14	---	74
Transverse for Deflection Limit L / 360	PSM80	8	---	120
	PSM80	10	---	103
	PSM80	12	---	87
	PSM80	14	---	71
Combined Axial and Transverse for Deflection Limit L / 120	PSM80	8	11000	178
	PSM80	10	11180	143
	PSM80	12	11350	107
	PSM80	14	11530	71
Combined Axial and Transverse for Deflection Limit L / 180	PSM80	8	11000	130
	PSM80	10	11180	106
	PSM80	12	11350	82
	PSM80	14	11530	57
Combined Axial and Transverse for Deflection Limit L / 240	PSM80	8	11000	106
	PSM80	10	11180	87
	PSM80	12	11350	69
	PSM80	14	11530	50
Combined Axial and Transverse for Deflection Limit L / 360	PSM80	8	11000	82
	PSM80	10	11180	69
	PSM80	12	11350	56
	PSM80	14	11530	44

For **SI**: 1 inch = 25.4 mm, 1 lb/ft = 14.6 N/m, 1 psf = 47.9 Pa.

TABLE 2—ALLOWABLE WALL PANEL RACKING SHEAR LOADS

TYPE OF LOADING	TYPE OF PANEL	PANEL HEIGHT (ft)	RACKING SHEAR LOAD (Pounds per linear foot)	DEFLECTION (inch)
Racking Shear	PSM80	8	770	0.06
	PSM80	10	840	0.16
	PSM80	12	910	0.25
	PSM80	14	980	0.35

For **SI**: 1 inch = 25.4 mm, 1 lb/ft = 14.6 N/m, 1 psf = 47.9 Pa.

TABLE 3—ALLOWABLE ROOF, FLOOR PANEL LOADS

TYPE OF LOADING	TYPE OF PANEL	SPAN (ft)	AXIAL COMPRESSIVE LOADS (Pounds per linear foot)	TRANSVERSE LOADS (Pounds per square foot)
Transverse for Deflection Limit L /120	PSS80	8	---	304
	PSS80	12	---	119
	PSS150	8	---	345
	PSS150	12	---	135
Transverse I for Deflection Limit L /180	PSS80	8	---	254
	PSS80	12	---	101
	PSS150	8	---	274
	PSS150	12	---	110
Transverse for Deflection Limit L /240	PSS80	8	---	229
	PSS80	12	---	91
	PSS150	8	---	238
	PSS150	12	---	98
Transverse for Deflection Limit L /360	PSS80	8	---	203
	PSS80	12	---	82
	PSS150	8	---	202
	PSS150	12	---	85

For **SI**: 1 inch = 25.4 mm, 1 lb/ft = 14.6 N/m, 1 psf = 47.9 Pa.

TABLE 4—ALLOWABLE ROOF, FLOOR PANEL DIAPHRAGM SHEAR LOAD

TYPE OF LOAD	TYPE OF PANEL	SPAN (ft)	DIAPHRAGM SHEAR LOAD (Pounds per linear foot)	DEFLECTION AT ALLOWABLE SHEAR LOAD
Diaphragm Shear	PSS80	8	430	0.17

For **SI**: 1 inch = 25.4 mm, 1 lb/ft = 14.6 N/m, 1 psf = 47.9 Pa.

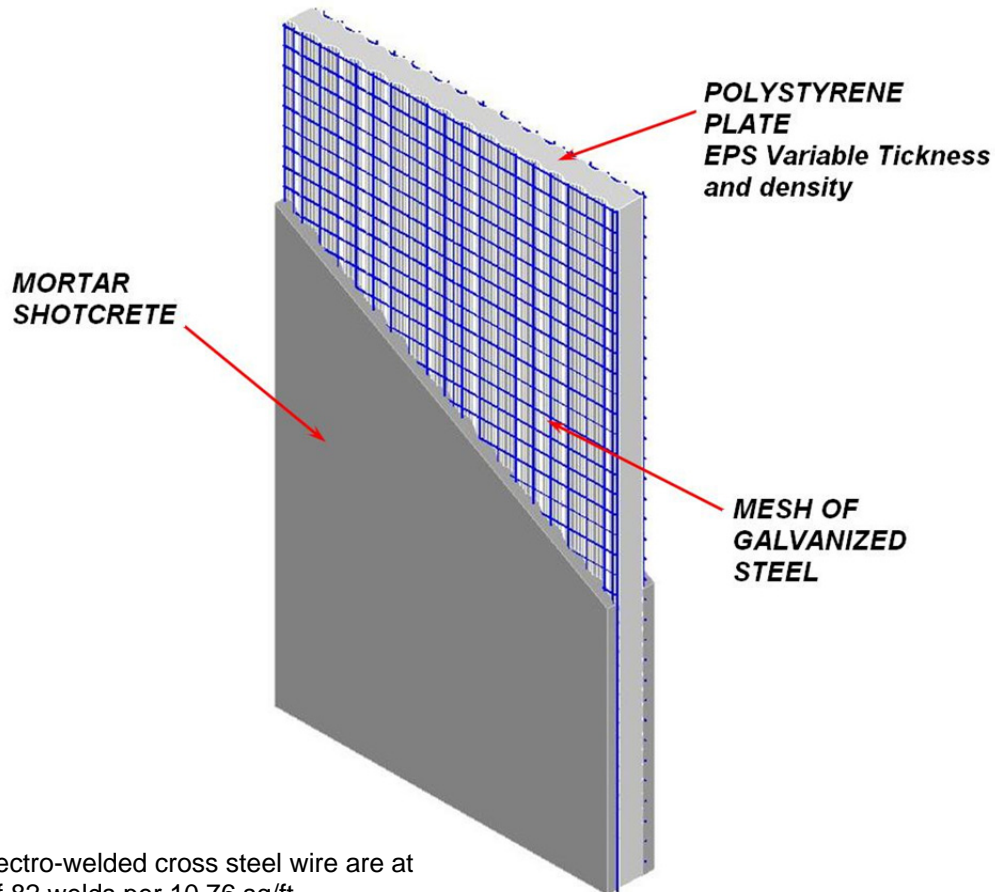

Note: Electro-welded cross steel wire are at a ratio of 82 welds per 10.76 sq/ft

FIGURE 1—TYPICAL INSTALLATION DETAILS

GENERAL DETAILS

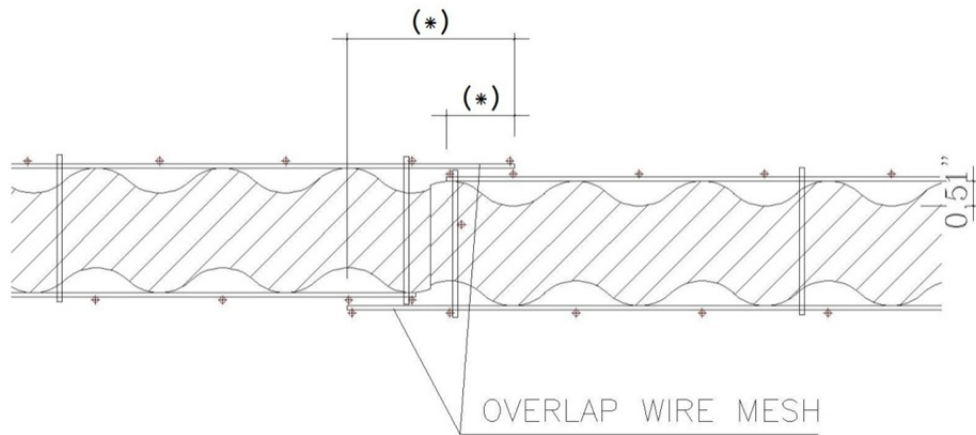

Note: (*) to be design by engineer of records

PANEL TO PANEL CONNECTION/JOINT

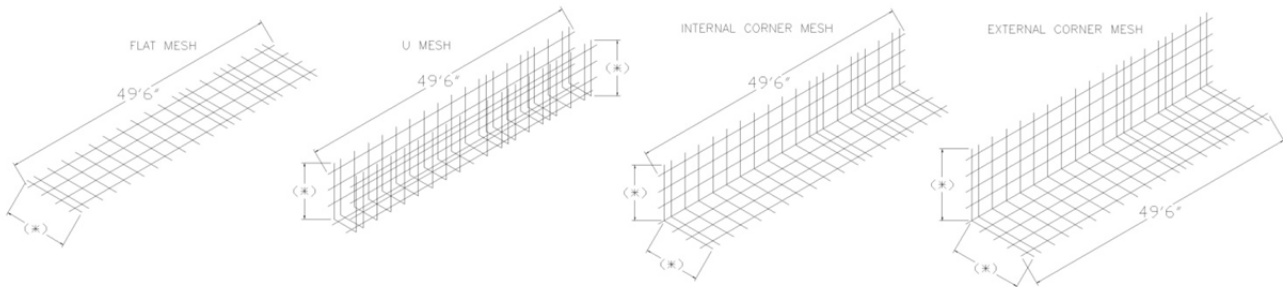

Note: (*) to be design by engineer of records

FIGURE 1—TYPICAL INSTALLATION DETAILS (Continued)

TYPICAL TYPES OF MESH USED FOR REINFORCEMENT/CONNECTION

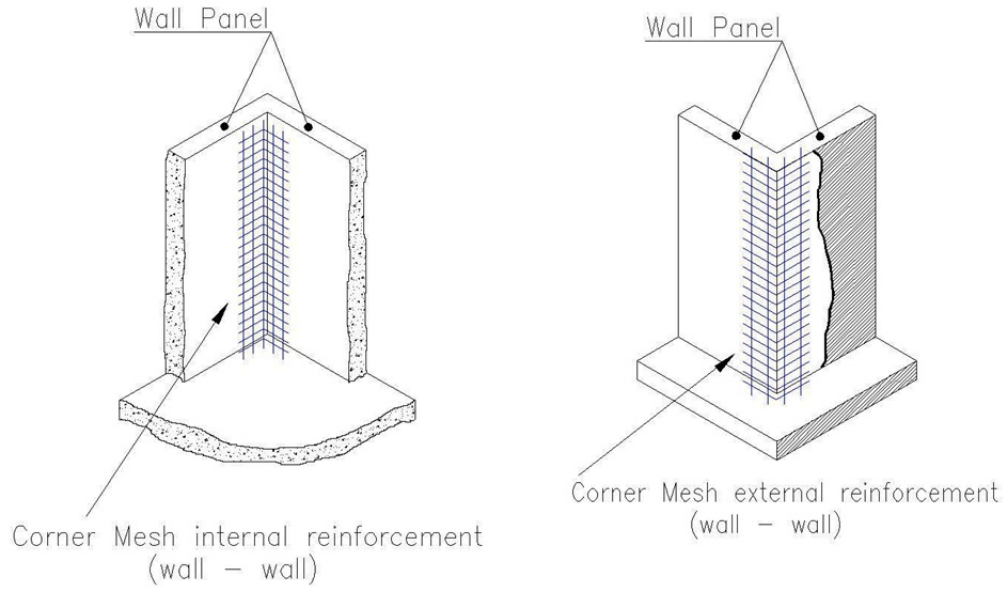

WALL PANEL TO WALL PANEL CORNERS CONNECTIONS

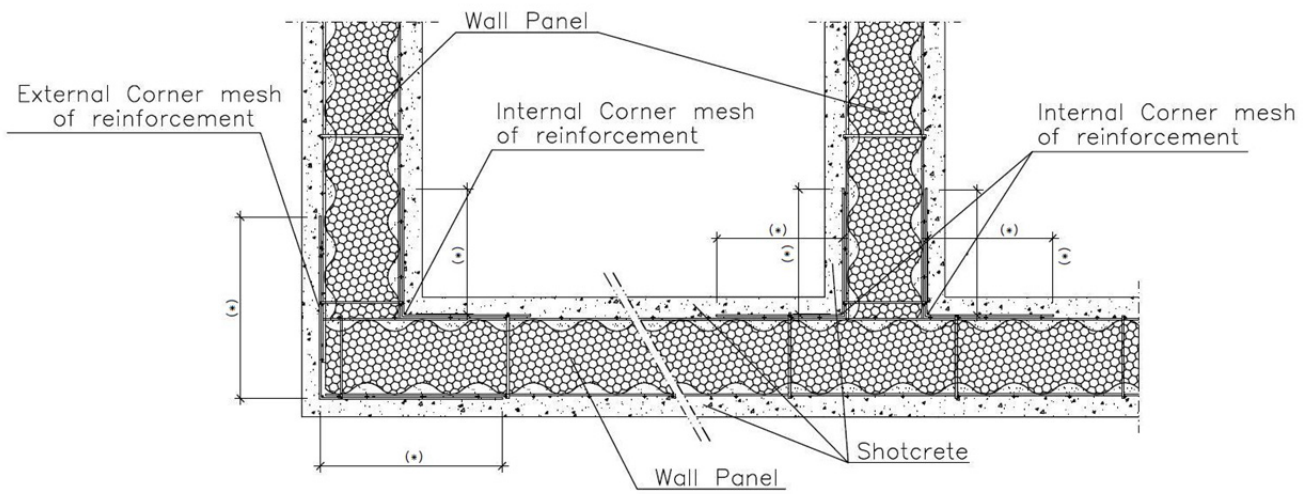

Note: (*) to be designed by engineer of records

FIGURE 1—TYPICAL INSTALLATION DETAILS (Continued)

WALL PANEL TO FOUNDATION CONNECTION

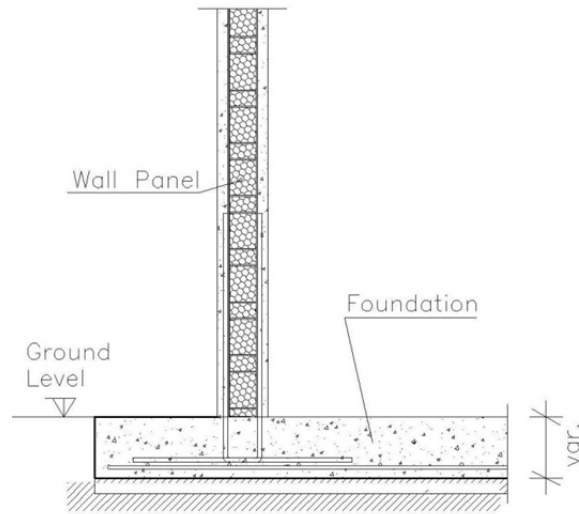

EXTERIOR WALL PANEL TO FLOOR/ROOF PANEL CONNECTION

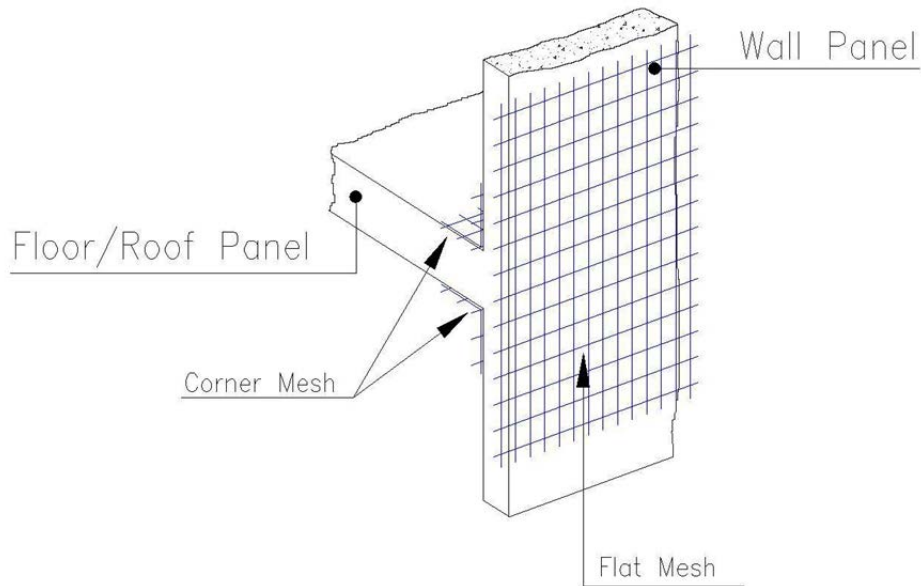
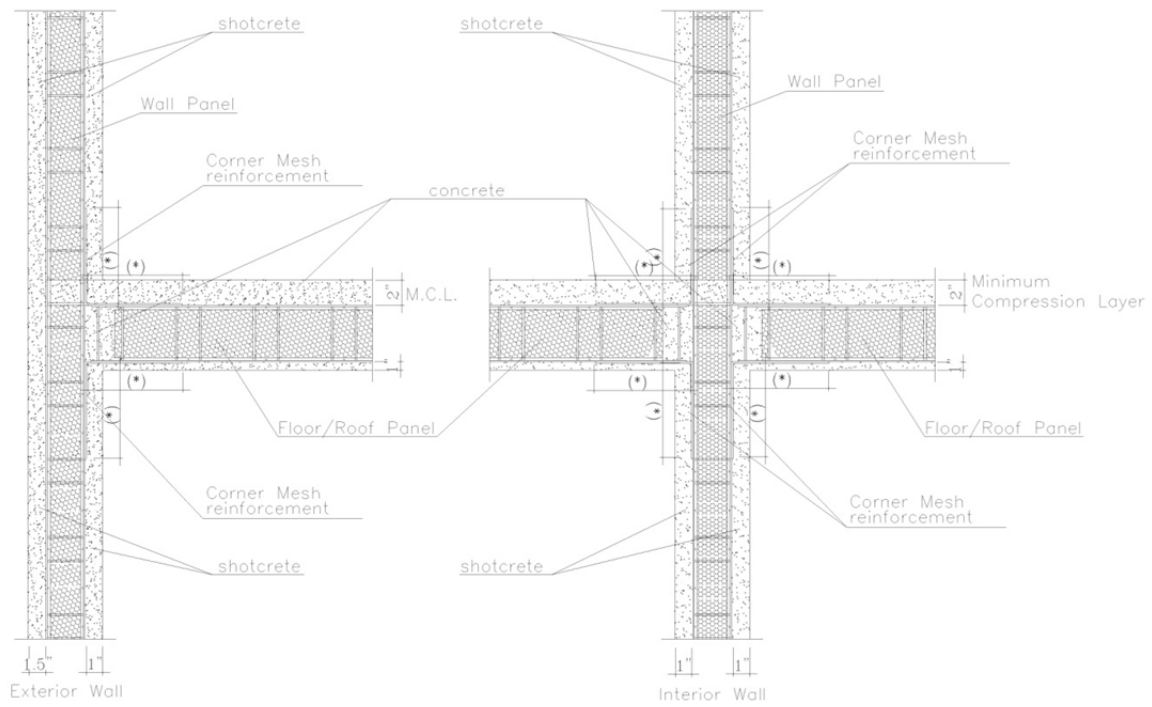

FIGURE 1—TYPICAL INSTALLATION DETAILS (Continued)

WALL PANEL TO FLOOR/ROOF PANEL CONNECTION



Note: (*) to be designed by engineer of records

WALL PANEL TO ROOF PANEL CONNECTION

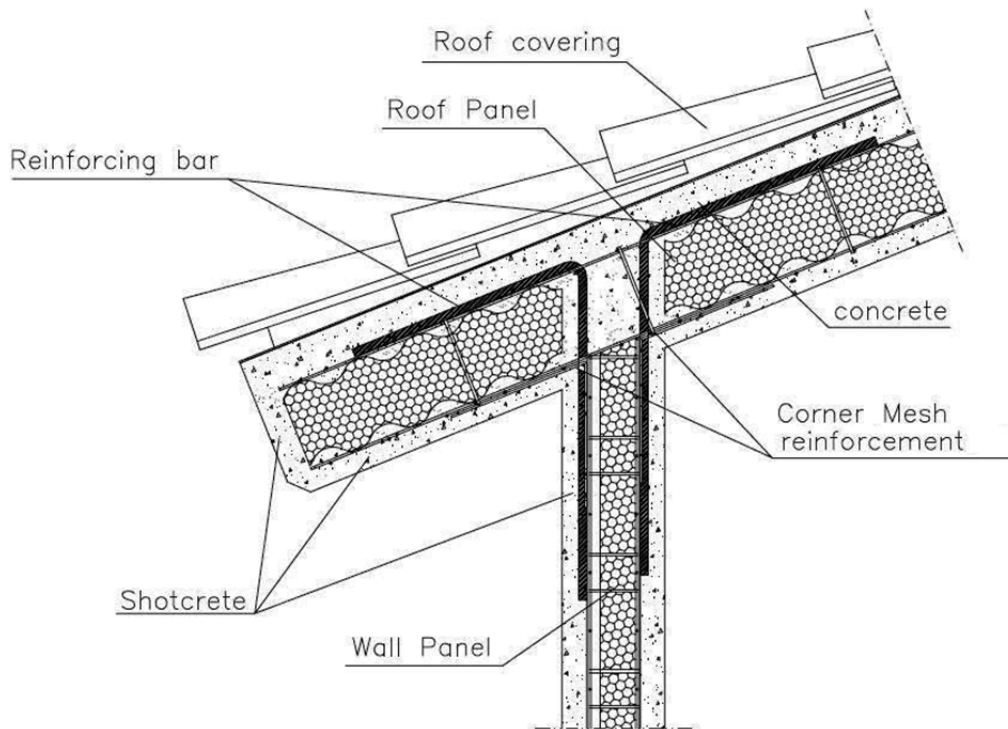

FIGURE 1—TYPICAL INSTALLATION DETAILS (Continued)